

Parcel	AREA		IMPERVIOUS
	Square Feet	Acres	
LOT 1	12,910.83	0.296	3,400.00
LOT 2	12,964.67	0.298	3,400.00
LOT 3	11,948.80	0.274	3,400.00
LOT 4	10,201.10	0.234	3,400.00
LOT 5	9,685.57	0.222	3,400.00
COS 1	1,898.00	0.044	0.00
COS 2	5,125.08	0.118	0.00
Prop. ROW	6,344.41	0.146	0.00
Total	71,078.46	1.63	17,000.00

Prop. ROW	6,344.41	4,475.17
-----------	----------	----------

Project Impervious = 17,000.00 sf
 Percent Impervious Project = 23.92%

**Impervious percent for project does not include ROW
 impervious area per meeting - 11/14/17

OWNER
 OAKBROOKE, INC.
 128 SADIE LANE
 MOORESVILLE, NC 28115
 PHONE: (704) 728-2654

SITE INFORMATION
 PROPOSED 5-LOT SUBDIVISION
 PARCEL #: 00318205 AND PORTION OF 00318227

QUEEN STREET
 CORNELIUS, NC 28031

CURRENT SITE AREA:
 1.056 AC
 0.574 AC
 TOTAL = 1.630 AC
 EXISTING ZONING: NEIGHBORHOOD MIXED USE (NMX)
 PROPOSED ZONING: CZ

DEED BOOK/PAGE:
 DB-30587 PG-171
 DB-30127 PG-747

GARBAGE: ROLL OUT CANISTER

SITE DATA
 FRONT SETBACK: 30 FT (MAX)
 SIDE SETBACK: 5 FT
 REAR SETBACK: 40 FT
 HEIGHT: 36 FT

WATERSHED DATA
 LAKE NORMAN IV - CA

BASE ON PRESUBMITTAL MEETING ON NOVEMBER 14,
 2017. NO DETENTION OR WATER QUALITY WILL BE
 REQUIRED FOR THIS PROJECT.

THE PROJECT IS LIMITED TO 24% IMPERVIOUS AREA.

FLOOD DATA
 THE PROPERTY LIES WITHIN "ZONE X" ACCORDING TO
 THE FLOOD INSURANCE RATE MAP: COMMUNITY PANEL
 NUMBER: 3710464300K. EFFECTIVE DATE SEPTEMBER 2,
 2015.

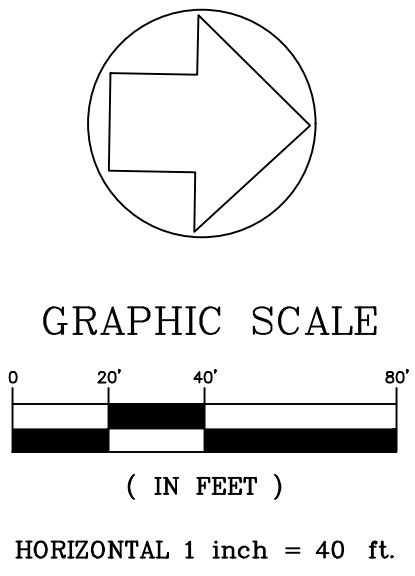

BLUESTONE
LAND MANAGEMENT, PLLC

470 NORTH BRAD STREET, SUITE A
 MOORESVILLE, NC 28145
 (704) 649-8869
 bluestonelandmanagement.com
 NC License #: P-1444

PRELIMINARY
 NOT RELEASED FOR
 CONSTRUCTION

NO.	DATE	BY	REVISION
1	10/27/17	JAC	MEETING WITH TOWN OF CORNELIUS
2	11/01/17	JAC	ADDED LOTS 4 AND 5
3	11/16/17	JAC	REVISED PER MEETING WITH TOWN AND COUNTY
4	11/18/17	JAC	ADDED CLARIFICATION ON BUFFERS. ADDED TO COS 2
5	11/18/17	JAC	CORRECTED NOTE ON IMPERVIOUS CHART

QUEEN STREET PROPERTY

CORNELIUS, NORTH CAROLINA

OAKBROOKE INC.
 128 SADIE LANE
 MOORESVILLE, NORTH CAROLINA 28115

ANY REPRODUCTION OR OTHER USE OF THIS DOCUMENT WITHOUT PERIODIC PERMISSION FROM BLUESTONE LAND MANAGEMENT, PLLC IS EXPRESSLY PROHIBITED.

PROJECT #: 2017-0002 DATE: 10/17/17
 DRAWN BY: JAC CHECKED BY: JAC

TITLE
CONCEPT PLAN

SHEET
CP-1.0

Z:\Blum\Projects\2017\2017-0002-Queen Street Subdivision - John Ogburn\CADD\Concept\CP-1.0-Concept-Queen.dwg DATE